

# ULTRAMINI

Bohrungsbearbeitung  
ab  $\varnothing 0.2$  mm

grooving, boring and profiling  
starting at  $\varnothing 0.2$  mm

# Typ 070

Vorstechen und Fasen

D min. 4.0 - 6.0 mm

pregrooving and chamfering

D min. 4.0 - 6.0 mm

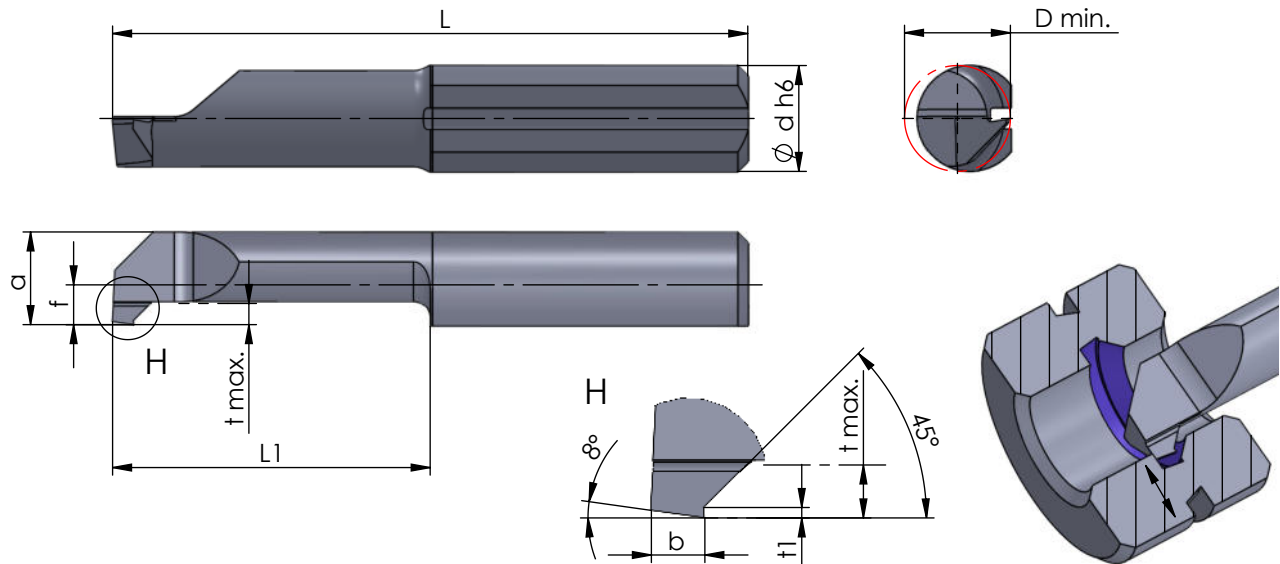

Rechts (R): wie gezeichnet  
Links (L): spiegelbildlich

righthand (R): as shown  
lefthand version (L): mirror image

Abmessungen in mm

dimensions in mm

Bestellnummer part number	t1	b	f	a	L	L1	t max.	D min.	$\varnothing d h6$	K10F CN45F AL41F P07C	Klemmhalter Typ toolholder type	
											645...	640... ...4 650... ...5
R/L 070.4-10	0.2	1.0	1.5	3.5	25	10	0.8	4.0	4.0	● ● ●	645...	640... ...4
R/L 070.4-16	0.2	1.0	1.5	3.5	30	16	0.8	4.0	4.0	● ● ●		650... ...5
R/L 070.5-15	0.2	1.0	1.9	4.4	30	15	1.0	5.0	5.0	● ● ●	645...	650... ...5
R/L 070.5-20	0.2	1.0	1.9	4.4	35	20	1.0	5.0	5.0	● ● ●		
R/L 070.5-30	0.2	1.0	1.9	4.4	45	30	1.0	5.0	5.0	● ● ●		
R/L 070.6-30	0.2	1.0	2.3	5.3	45	30	1.0	6.0	6.0	● ● ●	660... 676... ...6	
R/L 070.6-42	0.2	1.0	2.3	5.3	57	42	1.0	6.0	6.0	● ● ●		

Weitere HM Sorten können Sie in der Sortenübersicht im Kapitel "Technische Hinweise" und der Preisliste finden.

Bestellbeispiel:  
für rechte Ausführung und Sorte  
R070.4-10/CN45F

More carbide grades you can find in the grades summary in the chapter "technical instructions" and in the price list.

order-example:  
righthand version and grade  
R070.4-10/CN45F