

SYSTEM 500

Nut- und Trennfräsen

groove milling
and slotting cutter

Typ 514

Fräswendeschnleidplatte,
für metrisches ISO-Gewinde,
Vollprofil, innen

indexable milling insert,
metric ISO-thread,
full profile, internal

Steigung P = 1.5 - 5.5

pitch P = 1.5 - 5.5

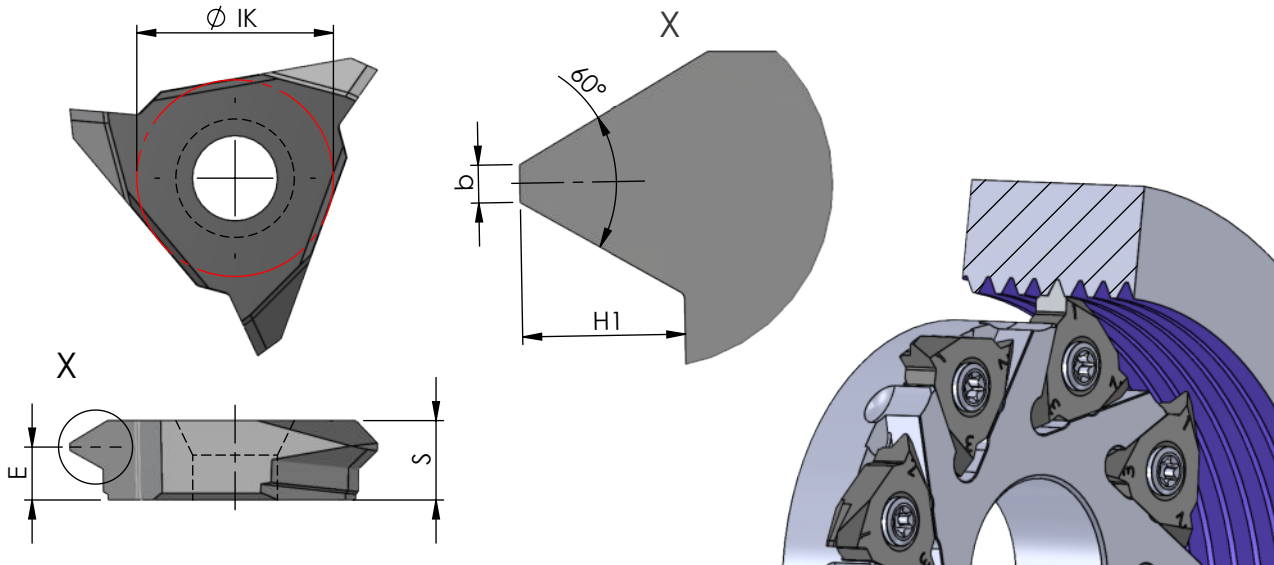

Abmessungen in mm

dimensions in mm

Bestellnummer part number	Steigung P pitch P	S	E	b	H1	Ø IK -0.03	K10F AL41F P18C	für Fräseschaft / Messerkopf for milling shank / milling cutter
514.0815.02	1.5	5.25	4.4	0.19	0.81	13	●	
514.1020.02	2.0	5.25	4.2	0.25	1.08	13	●	
514.1630.02	3.0	5.25	3.9	0.38	1.62	13	●	
514.1835.02	3.5	5.25	3.7	0.44	1.89	13	●	500...
514.2140.02	4.0	5.25	3.5	0.5	2.17	13	●	510...
514.2445.02	4.5	5.25	3.3	0.56	2.44	13	●	581...
514.2750.02	5.0	5.85	3.8	0.62	2.71	13	●	
514.2955.02	5.5	5.85	3.6	0.69	2.98	13	●	

Weitere HM Sorten können Sie in der Sortenübersicht im Kapitel "Technische Hinweise" und der Preisliste finden.

Bestellbeispiel:
für Sorte AL41F:
514.0815.02/AL41F

More carbide grades you can find in the grades summary in the chapter "technical instructions" and in the price list.

order-example:
grade AL41F:
514.0815.02/AL41F