

**MINIMILL**

Nut- und Formzirkularfräsen

groove milling by circular interpolation

**Typ Z610**

Vorwärts- und Rückwärtsfasen

forward & backward chamfering

D min. 10 mm

D min. 10 mm

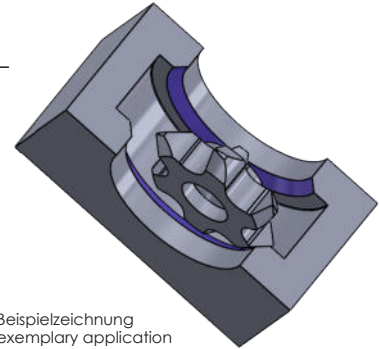
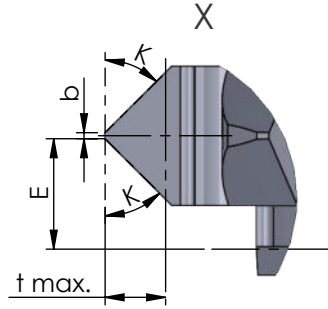
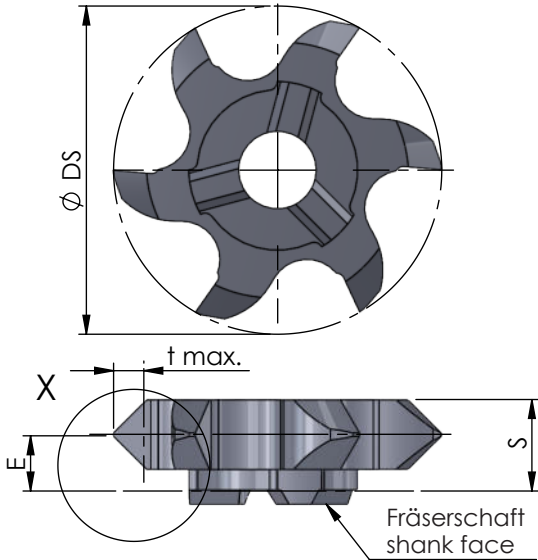

Abmessungen in mm

dimensions in mm

Bestellnummer part number	K	D min.	S	E	Ø DS	b	t max.	Zähnezahl number of teeth	Material			für Frälerschaft for milling shank
									K10F	AL41F	P18C	
Z610.1515.02	15°	10	3.6	1.8	9.7	0.2	0.35	6	●			
Z610.2020.02	20°	10	3.6	1.8	9.7	0.2	0.45	6	●			
Z610.3030.02	30°	10	3.6	1.8	9.7	0.2	0.7	6	●			
Z610.4545.02	45°	10	3.6	1.8	9.7	0.2	1.2	6	●			ZH10...

Weitere HM Sorten können Sie in der Sortenübersicht im Kapitel "Technische Hinweise" und der Preisliste finden.

Bestellbeispiel:  
für Sorte AL41F:  
Z610.1515.02/AL41F

More carbide grades you can find in the grades summary in the chapter "technical instructions" and in the price list.

order-example:  
grade AL41F:  
Z610.1515.02/AL41F