

MIKROMILL

Nut- und Formzirkularfräsen

groove milling
by circular interpolation

Typ MA3 / MA5 / MA6 / MA8

metrisches ISO-Feingewinde,
Teilprofil, innen

metric ISO-fine thread,
partial profile, internal

ab Gewindegröße M1.0 x 0,25

starting at thread size M1.0 x 0,25

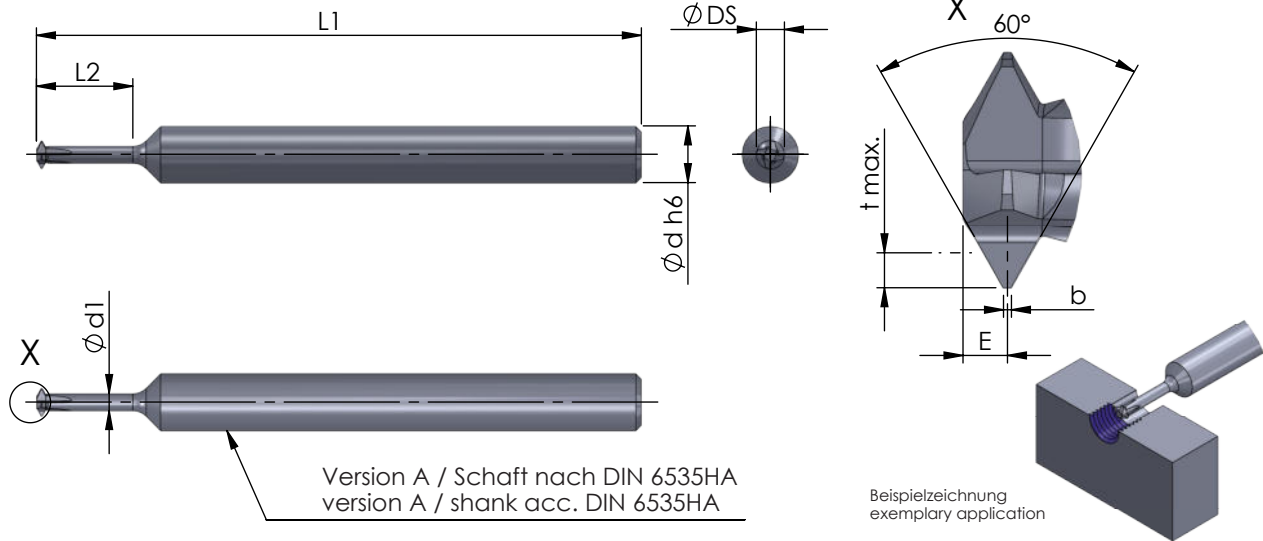

Abmessungen in mm

dimensions in mm

| Bestellnummer part number | D min. | Steigung P pitch P | min. Gewindegröße min. thread size * Feingewinde / fine thread | L2 | L1 | b | E | t max. | Ø d h6 | Ø d1 | Ø DS | Schneidenzahl cutting edge | | | |
|------------------------------|--------|-----------------------|-------------------------------------------------------------------------|-----|----|------|-----|--------|--------|------|------|-------------------------------|------|-------|------|
| | | | | | | | | | | | | | K10F | AL41F | P18C |
| MA3.0025.01-2 | 0.75 | 0.25 | M1.0 | 2.5 | 32 | 0.03 | 0.2 | 0.14 | 3 | 0.33 | 0.7 | 3 | ● | | |
| MA3.0035.01-4 | 1.38 | 0.35 | M1.6 | 4 | 32 | 0.04 | 0.2 | 0.19 | 3 | 0.67 | 1.18 | 3 | ● | | |
| MA3.0035.01-5 | 1.58 | 0.35 | M1.8 | 5 | 32 | 0.04 | 0.2 | 0.19 | 3 | 0.86 | 1.38 | 3 | ● | | |
| MA3.0040.01-5 | 2.07 | 0.4 | M2.5* | 5 | 32 | 0.05 | 0.3 | 0.22 | 3 | 0.92 | 1.5 | 4 | ● | | |
| MA3.0045.01-6 | 2.52 | 0.45 | M3.0* | 6 | 32 | 0.06 | 0.3 | 0.25 | 3 | 1.28 | 1.95 | 4 | ● | | |
| MA3.0050.01-7 | 2.96 | 0.5 | M3.5* | 7 | 32 | 0.06 | 0.3 | 0.27 | 3 | 1.67 | 2.4 | 4 | ● | | |
| MA3.0060.01-8 | 3.35 | 0.6 | M4.0* | 8 | 32 | 0.08 | 0.4 | 0.33 | 3 | 1.93 | 2.8 | 4 | ● | | |
| MA5.0070.01-9 | 3.74 | 0.7 | M4.5 | 9 | 44 | 0.09 | 0.4 | 0.38 | 5 | 2.12 | 3.1 | 4 | ● | | |
| MA5.0080.01-10 | 4.63 | 0.8 | M5.5 | 10 | 44 | 0.10 | 0.5 | 0.43 | 5 | 2.97 | 4.1 | 4 | ● | | |
| MA5.0100.01-12 | 5.92 | 1.0 | M7 | 12 | 44 | 0.13 | 0.6 | 0.54 | 5 | 3.51 | 4.9 | 4 | ● | | |
| MA5.0100.01-15 | 5.92 | 1.0 | M7 | 15 | 44 | 0.13 | 0.6 | 0.54 | 5 | 3.5 | 4.9 | 4 | ● | | |
| MA6.0815.01-15 | 6.0 | 0.5-1.5 | M7 | 15 | 58 | 0.06 | 0.8 | 0.92 | 6 | 3.5 | 5.8 | 3 | ● | | |
| MA8.0815.01-25 | 8.0 | 0.5-1.5 | M9 | 25 | 68 | 0.06 | 1.0 | 0.91 | 8 | 5.5 | 7.8 | 3 | ● | | |
| MA8.1020.01-25 | 8.0 | 1.0-2.0 | M10 | 25 | 68 | 0.12 | 1.0 | 1.19 | 8 | 5.0 | 7.8 | 3 | ● | | |

Weitere HM Sorten können Sie in der Sortenübersicht im Kapitel "Technische Hinweise" und der Preisliste finden.

Bestellbeispiel:
für Sorte AL41F:
MA3.0025.01-2/AL41F

More carbide grades you can find in the grades summary in the chapter "technical instructions" and in the price list.

order-example:
grade AL41F:
MA3.0025.01-2/AL41F