

NUTSTOSEN

von Längsnuten nach
DIN 138 und DIN 6885

broaching keyways according
DIN 138 und DIN 6885

Typ NP10.SW

Schneideinsatz
für Innensechskant

insert
for hexagon socket

Schlüsselweite ab SW 10 - 16 mm

wrench size from 10 - 16 mm

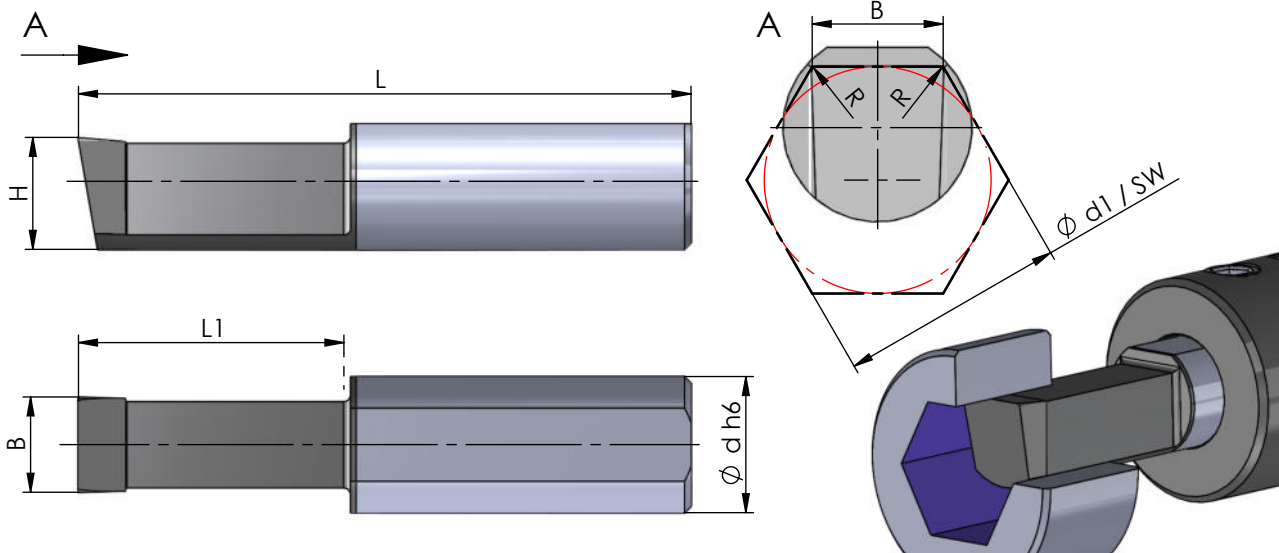

Nutmaß nach DIN		width of the groove according to DIN	
Abmessungen in mm		dimensions in mm	

Bestellnummer part number	Schlüsselweite SW wrench size	Ø d1 Bohrung Ø d1 hole	B	H +0.05	R	L	L1	Ø d h6	für Klemmhalter for toolholder type		
									K10F	AL41F	P18C
NP10.SW10.10.02	10	10	5.85	9.0	0.2	40	15	10	●		
NP10.SW12.12.03	12	12	7.02	8.2	0.3	45	20	10	●		NH10...
NP10.SW14.14.03	14	14	8.18	7.5	0.3	45	20	10	●		
NP10.SW16.16.04	16	16	9.34	6.2	0.4	50	25	10	●		



Weitere HM Sorten können Sie in der Sortenübersicht im Kapitel "Technische Hinweise" und der Preisliste finden.

Bestellbeispiel:
für Sorte AL41F:
NPU.SW10.10.02/AL41F

More carbide grades you can find in the grades summary in the chapter "technical instructions" and in the price list.

order-example:
grade AL41F:
NPU.SW10.10.02/AL41F