

NUTSTOSSEN

von Längsnuten nach
DIN 138 und DIN 6885

broaching keyways according
DIN 138 und DIN 6885

Typ NPV

Schneideinsatz
Nuttiefe bis 8.5 mm,
Toleranzklassen C11 / inch

B = 6 - 12

insert
depth of groove up to 8.5 mm,
tolerance grade C11 / inch

B = 6 - 12

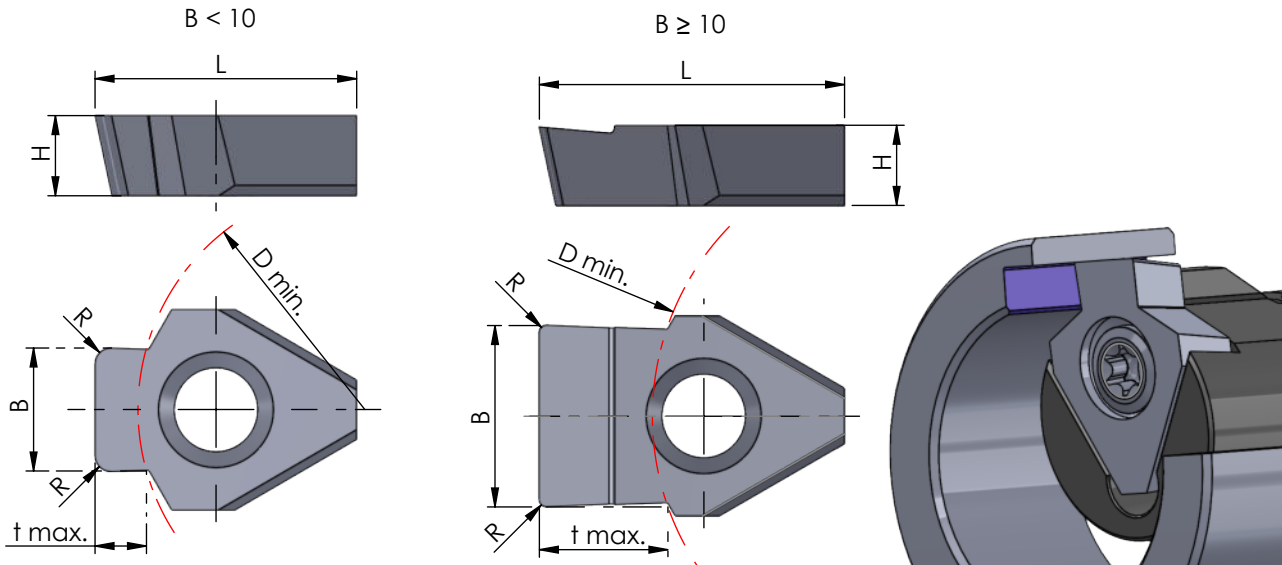

Abmessungen in mm

dimensions in mm

Bestellnummer part number	Nenngröße nominal size	Schneideinsatz nach DIN insert according DIN	B	B (inch)	R	L	t max.	H	Klemmhalter			für Klemmhalter for toolholder type
									K10F	AL41F	P18C	
NPV.0612.085	6	C11 DIN 138 Standard	6.12	0.241"	0.85	17.3	2.6	5.3	●	●	●	NHV.22...
NPV.0713.085	7		7.13	0.280"	0.85	17.3	3.3	5.3	●	●	●	NHV.22...
NPV.0813.105	8		8.13	0.317"	1.05	17.3	3.4	5.3	●	●	●	NHV.30... (NHV.22)
NPV.1013.105	10		10.13	0.395"	1.05	20.1	4.2	5.3	●	●	●	NHV.38..(NHV.30/22..)
NPV.1215.135	12		12.15	0.472"	1.35	20.1	5.1	5.3	●	●	●	NHV.38..(NHV.30/22..)
NPV.1215.175	12		12.15	12.15	1.75	20.1	6.6	5.3	●	●	●	NHV.38..(NHV.30/22..)
NPV.1215.225	12	12.15	12.15	2.25	20.1	8.5	5.3	●	●	●	NHV.38..(NHV.30/22..)	
NPV.U0638.02	1/4"	inch	6.38	0.251"	0.2	17.3	3.4	5.3	●	●	●	NHV.22...
NPV.U0797.02	5/16"		7.97	0.314"	0.2	17.3	4.1	5.3	●	●	●	NHV.22...
NPV.U0956.03	3/8"		9.56	0.377"	0.3	17.3	5.0	5.3	●	●	●	NHV.30... (NHV.22)
NPV.U1273.03	1/2"		12.73	0.502"	0.3	20.1	6.6	5.3	●	●	●	NHV.38..(NHV.30/22..)

Klemmhalter in Klammer sind nicht optimal in der Unterstützung. Schnittwerte reduzieren! Weitere HM Sorten können Sie in der Sortenübersicht im Kapitel "Technische Hinweise" und der Preisliste finden.

Bestellbeispiel:
für Sorte AL41F:
NPV.0612.085/AL41F

Please note that toolholders in brackets are not the optimal choice. If using them, please reduce the cutting data!

More carbide grades you can find in the grades summary in the chapter "technical instructions" and in the price list.

order-example:
grade AL41F:
NPV.0612.085/AL41F