

NUTSTOSEN

von Längsnuten nach
DIN 138 und DIN 6885

broaching keyways according
DIN 138 und DIN 6885

Typ NHV.15.IK25

Klemmhalter
mit Innenkühlung

D min. 15 mm

toolholder
with internal cooling

D min. 15 mm

innere Kühlmittelzufuhr
through coolant

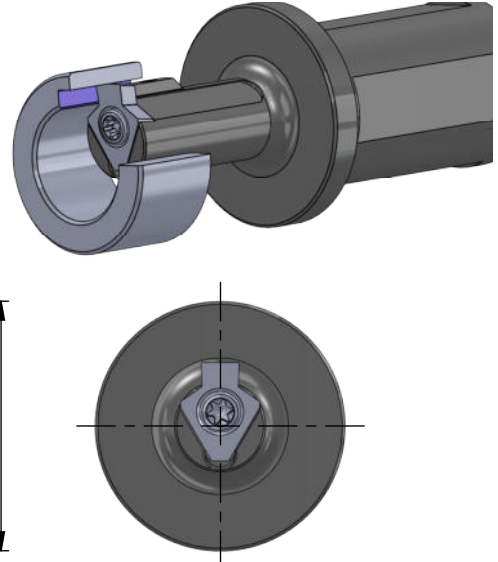
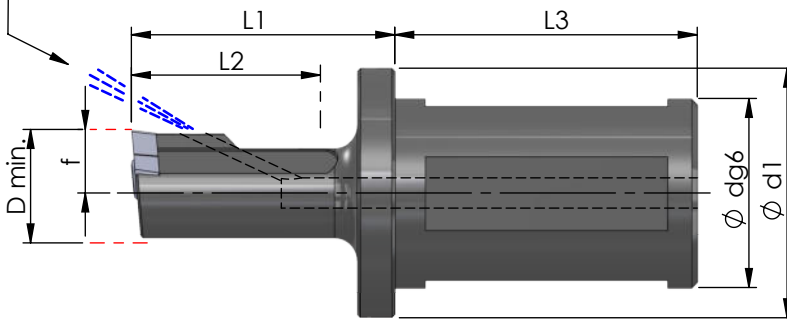

Abmessungen in mm

dimensions in mm

Bestellnummer part number	D min.	Ø d g6 x L3 Aufnahme clamping part	L1	L2	f	Ø d1	Spannschraube screw	Schraubenschlüssel wrench	Anzugs- drehmoment torque	für Schneidplatte for insert
NHV.15.IK25.1	15	Ø25 x 40	35	25	8.4	33	M4-NH15	TR15	4.0 Nm	NV15...
NHV.15.IK25.2	15	Ø25 x 40	50	40	8.4	33				
NHV.15.IK25.3	15	Ø25 x 40	70	60	8.4	33				
NHV.15.IK25.4	15	Ø25 x 40	85	75	8.4	33				

Bestellbeispiel:
NHV.15.IK25.1

order-example:
NHV.15.IK25.1