

NUTSTOSEN

von Längsnuten nach
DIN 138 und DIN 6885

broaching keyways according
DIN 138 und DIN 6885

Typ NH10

Klemmhalter

D min. 10 mm

toolholder

D min. 10 mm

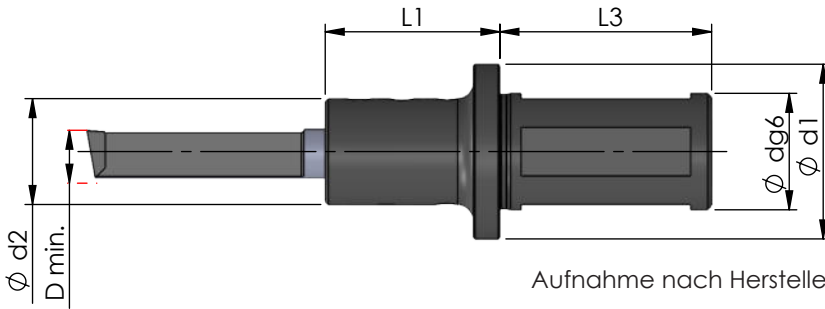

Aufnahme nach Herstellerangaben

clamping part according to
manufacture's specification

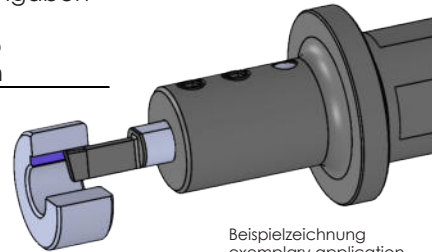
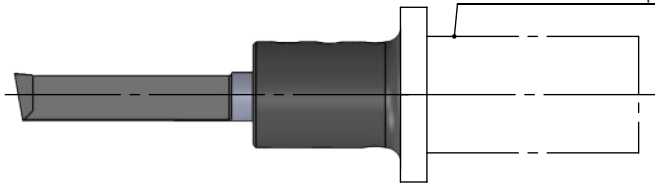

Beispielzeichnung
exemplary application

Abmessungen in mm

dimensions in mm

Bestellnummer part number	D min.	Ø d g6 x L3 Aufnahme clamping part	L1	Ø d1	Ø d2		Spannschraube screw	Schraubenschlüssel wrench	Anzugs- drehmoment torque	für Schneidplatte for insert
NH10.0020.1	10	Ø20 x 40	33	33	20					
NH10.0022.1	10	Ø22 x 40	33	33	20					
NH10.0025.1	10	Ø25 x 40	33	33	20		110.660	111.INB3	2.5 Nm	NP10,...
NH10.0032.1	10	Ø32 x 40	33	40	20					
Bestellnummer part number	D min.	Aufnahme nach Herstellerangabe clamping part acc. to manufac. specification			Ø d2	für Nutstossergeräte for broaching device	Spannschraube screw	Schraubenschlüssel wrench	Anzugs- drehmoment torque	für Schneidplatte for insert
NH10.0012.1	10	Ø12 x 25	32		20	Schwarzer 1				
NH10.0015.1	10	Ø15 x 33	37		18	Schwarzer 2 in 1				
NH10.0016.1	10	Ø16 x 30	33		18	EWS Slot + Benz LinA				
NH10.MP16.1	10	Ø16 x 34	33		20	Mario Pinto Stoßeinheit	110.660	111.INB3	2.5 Nm	NP10,...
NH10.MT16.1	10	Ø16 x 25	33		18	MT Marchetti				
NH10.WT16.1	10	Ø16 x 6	36		20	WTO Stoßeinheit				

Bestellbeispiel:
NH10.0020.1

order-example:
NH10.0020.1

