

# MINICUT

Bohrungsbearbeitung

grooving, boring and profiling

# Typ Gewindedrehen

NPT Vollprofil,  
innen

D min. 8 mm

type threading,  
NPT full profile, internal

D min. 8 mm

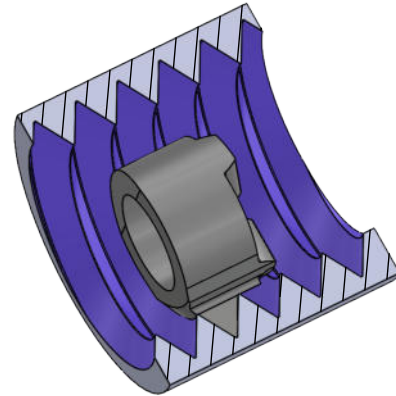
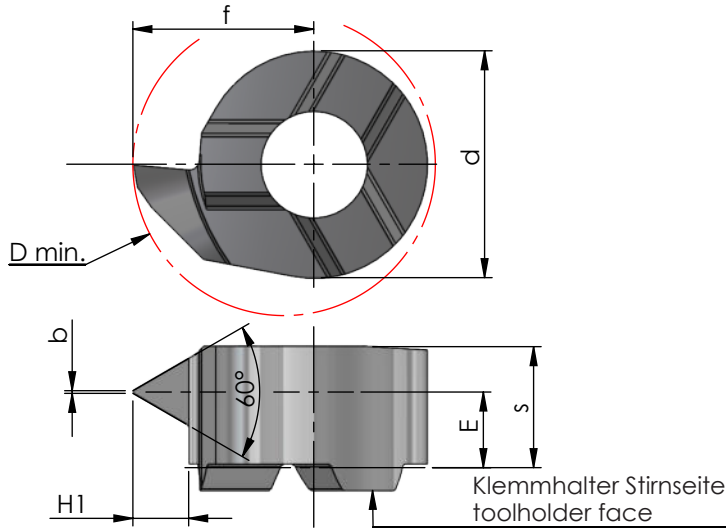

Rechts (R): wie gezeichnet  
Links (L): spiegelbildlich

righthand (R): as shown  
lefthand version (L): mirror image

Abmessungen in mm

dimensions in mm



Bestellnummer part number	Steigung P pitch P	H1	Gang / Zoll threads / inch	b	f	s	d	E	D min.	K10F	AL41F	P18C	Klemmhalter Typ toolholder type
R/L S08.NP14.02	1.814	1.48	14	0.07	4.8	3.2	6	2.0	8	●			
R/L S08.NP18.02	1.411	1.19	18	0.05	4.8	3.5	6	2.6	8	●			608
R/L S08.NP27.02	0.940	0.80	27	0.04	4.8	3.5	6	2.8	8	●			

Weitere HM Sorten können Sie in der Sortenübersicht im Kapitel "Technische Hinweise" und der Preisliste finden.

Bestellbeispiel:  
für rechte Ausführung und Sorte  
RS08.NP14.02/AL41F

More carbide grades you can find in the grades summary in the chapter "technical instructions" and in the price list.

order-example:  
righthand version and grade  
RS08.NP14.02/AL41F